

Model Limbus 105

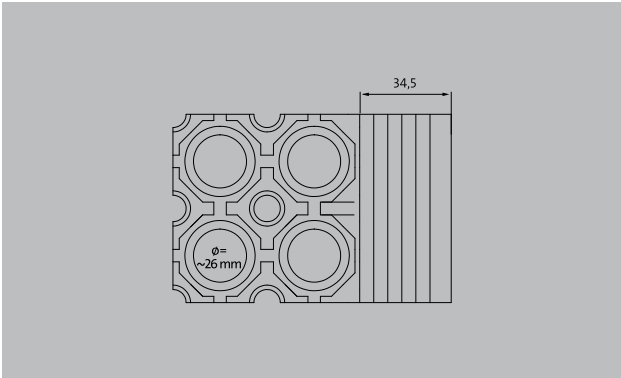

Ideal for entrances in outdoor areas without mat well or frame.

- 1 Outside (Zone 1)
- 2
- 3

Description

Mat with good cleaning effect and ideal water drainage system combined with low construction height. Easy to clean and material has a high level of temperature resistance (-30 to +50 °C)



Outside (Zone 1)



Outside (Zone 1)



Street dust, hair, sand, ash, textile fibres, small leaves and twigs, loose chippings, coarse sand, small gravel particles

Colours



Rubber honeycomb mat: black

emco LIMBUS without double ring round brushes

Model Limbus 105

Approx. height (mm)	10.5
Weight (kg/m²)	06,3
Tread surface	Octagonal honeycomb pattern with leading edge at side. Dimensional tolerance +/- 1.5%
Material	High-quality solid rubber, weather-proof and abrasion-proof

Water drainage	Ribs on the underside combined with open honeycomb bases ensure good water drainage even where the construction height is low
Custom mats	Can be cut to rectangular shapes (only possible without leading edge)
Panel size in mm	1520 x 920

Subject to technical modifications

emco Bautechnik GmbH · Breslauer Straße 34 - 38 · D-49808 Lingen (Ems)
· Germany · Phone: +49 (0) 591/9140-500 · Fax: +49 (0) 591/9140-852 · Email:
bau@emco.de · www.emco-bau.com

